

**UCLA**

# Marina Aquatic Center

**310-823-0048**

[www.recreation.ucla.edu/mac](http://www.recreation.ucla.edu/mac)

mac@saonet.ucla.edu

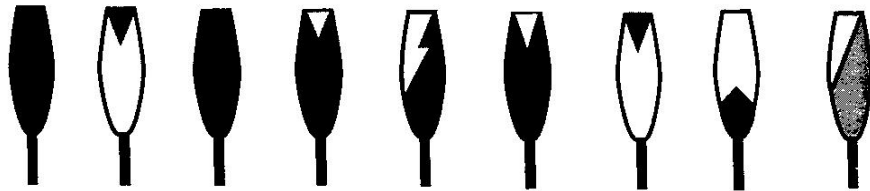

## ROWING MANUAL



**\$4.00**



# TABLE OF CONTENTS

## **INTRODUCTION TO ROWING**

1. Ten Things to Know About Rowing

## **SECTION 1: THE ROWING STROKE**

## **SECTION 2: NAVIGATING MARINA DEL REY**

## **SECTION 2: SCULLING**

1. Your First Row
2. Sculling Equipment
3. Sculling Technique
4. Technique Problems
5. Capsize Recovery

## **SECTION 3: SWEEP ROWING**

1. Your First Row
2. Sweep Rowing Equipment
3. Sweep Rowing Technique
4. Technique Problems
5. The Coxswain

## **SECTION 4: CONDITIONING**

1. Conditioning for Rowing
2. Rowing Workouts and Drills
3. Glossary

## **INTRODUCTION TO ROWING**

### Ten Things to Know About Rowing

1. There are two types of rowing – sculling and sweep rowing.
2. Rowing is one of the oldest competitive sports.
3. Elite rowers are typically very tall as height translates into a longer stroke.
4. Rowers are the largest contingent on the U.S. Olympic Team.
5. Rowing is regarded by exercise physiologists as one of the most physically demanding sports.
6. In rowing, distances are measured in meters.
7. Most international rowing regattas are contested on straight 2000-meter racecourses.
8. Rowing is one of the few sports where novices can become elite rowers within a few years.
9. Rowing is fun.
10. Rowing is a non-impact sport and can be done for life.

Become a part of the tradition. Enjoy your experience at the UCLA Marina Aquatic Center!

# SECTION 1: THE ROWING STROKE

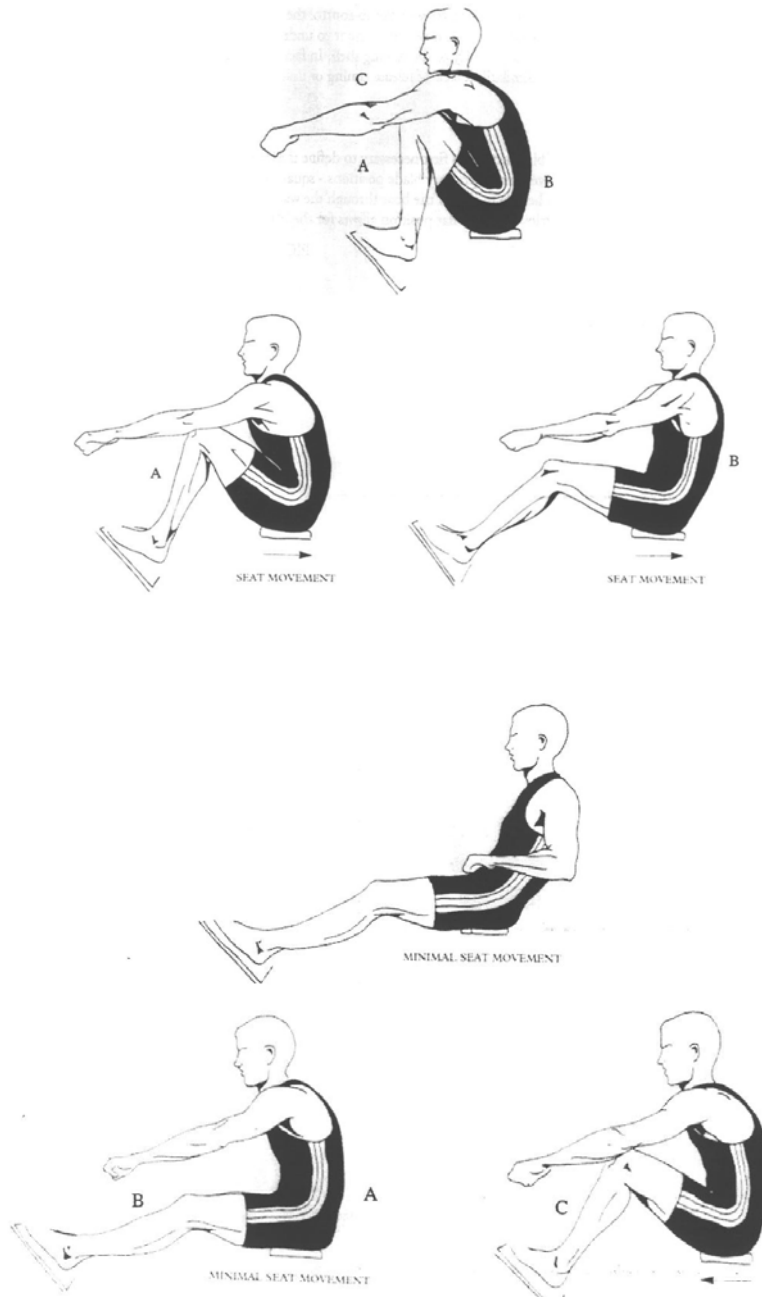

# THE CATCH

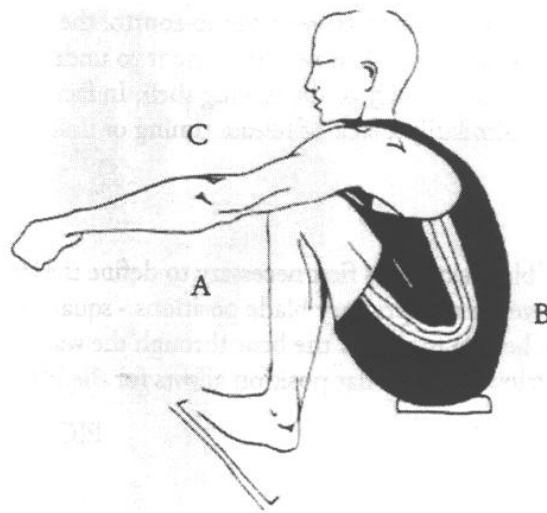

## **The Catch**

The Catch is the point at which the blades are inserted into the water.

## **The Catch Body Position**

The legs are held with the shins at a 90-degree angle relative to the boat (A), a position known as full slide. In this position the heels will naturally lift off the footplate of the stretcher. The back is held straight and leaning forward with the shoulders relaxed (B). It is important that the forward body angle at the catch be obtained from the hips and not from the lower back. Each hand should hold an oar while the thumbs are pressed against the ends of the grips to keep the oars in the oarlock. The arms should be fully extended with the knuckles, wrists, and elbows forming a straight line (C). The body should remain centered over the long axis of the boat, as all motion will occur along this line. The arms will follow the arcs of the oars around at the catch while the body remains centered.

Once the body is in the position described above, the blades are inserted into the water. This motion completes the slide forward and begins the pulling and is accomplished when the rower exerts upward pressure on the oar handles placing the already squared blades into the water. It is important to remember that the rowing stroke is a cycle of motion, and there should be no stopping between the end of the recovery, the catch motion, and the beginning of the drive.

## **The Catch Blade Position**

The blade is held square as it enters the water. It is important to prepare for the catch by squaring the blades before reaching full compression with the legs, the catch position described above. The hands should be lifted as the seat nears the frontstops so that the blades enter the water still traveling toward the bow of the shell. It is important that the continuity of the stroke be maintained with an early entry of the blades into the water.

# THE DRIVE

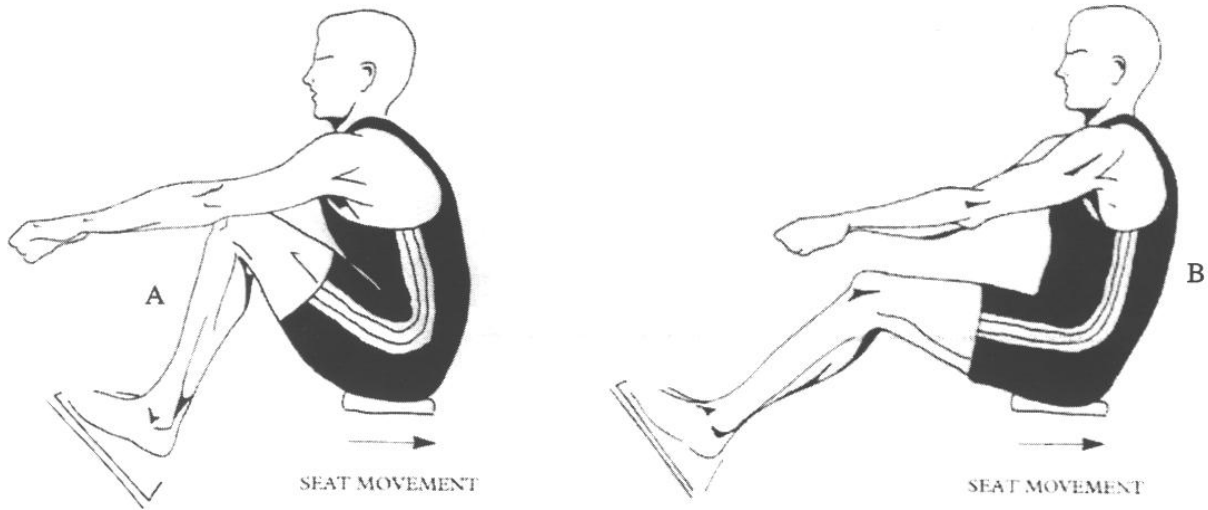

## The Drive

The Drive is the work portion of the rowing stroke, when the blades are in the water and the rower is pulling on the handles.

## The Drive Body Positions

The drive may be divided into three parts based on the dominant muscle group used during each portion. The order of these parts, or the sequence of muscle groups used, is determined by the relative strength or potential power of each. By employing the parts of the body in the order outlined below, the rower is able to continuously accelerate the oars throughout the stroke. When sculling, all motion during the drive should occur along the long axis of the boat, with all body movement synchronized. Outlined below are the three parts of the drive in the order that they should occur.

1. Leg Drive
2. Back Swing
3. Arm Draw (continued on next page)

### The Leg Drive:

The leg drive begins as the blade enters the water at the catch (see The Catch), with the shins at a 90-degree angle relative to the seat deck, arms fully extended, back straight and leaning forward, and the chin level. The legs initiate the stroke when the blades enter the water, with the back staying in its original angle until the legs are about halfway extended (A). To maximize the propulsive force of the leg drive the back should be held firm and not allowed to open until the legs have completed half of their extension.

### The Back Swing:

With the legs continuing their extension the body begins to swing toward the bow of the boat. This opens the body angle through the upright position (B), adding the body weight to the power of the legs. The back swing is empowered by the fact that as the back begins to move, the oars are at or around a 90-degree angle to the boat, a position, which physics dictates as the point at which maximum leverage, is possible.

## THE DRIVE (CONT.)

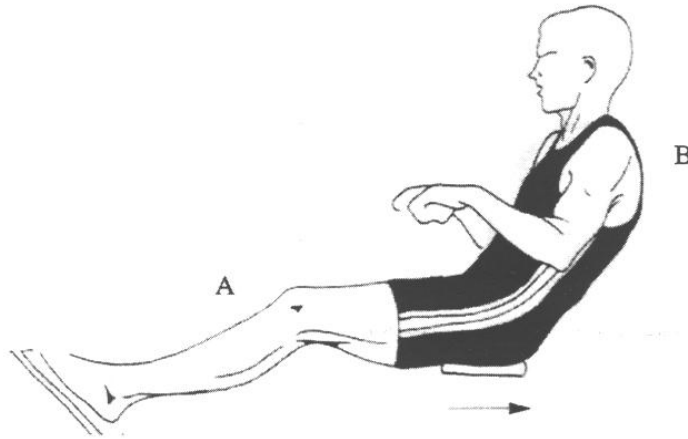

### The Arm Draw:

The final portion of the drive, the arm draw, begins as the back swings through perpendicular. It is important to wait until this point, as an earlier use of the arms will result in a diminished capacity for acceleration. The arms should draw the oar handles towards the chest as the legs maintain their pressure against the footboards (A). As the oars near the body, the shoulders should be relaxed, the back straight, and the wrists as flat as possible (B). During the arm draw the handles will briefly overlap with the left hand leading and above the right. In sculling, as previously mentioned, the hands and arms should follow the arcs of the oars. Thus, at the finish, the hands are drawn toward the outside of the lower chest in arcs termination at the rib cage.

### **The Drive Blade Positions**

The blades remain square throughout the drive. It is important to keep the blades at the surface of the water by ensuring the hands travel in a level path back to the lower chest. If the blades go too deep they will become unstable and the effectiveness of the drive will be compromised. This is known as “going deep.” A similar lack of propulsion results when the hands are kept too low. This flaw in technique, explained in full later, is known as “washing out.”

# THE RELEASE

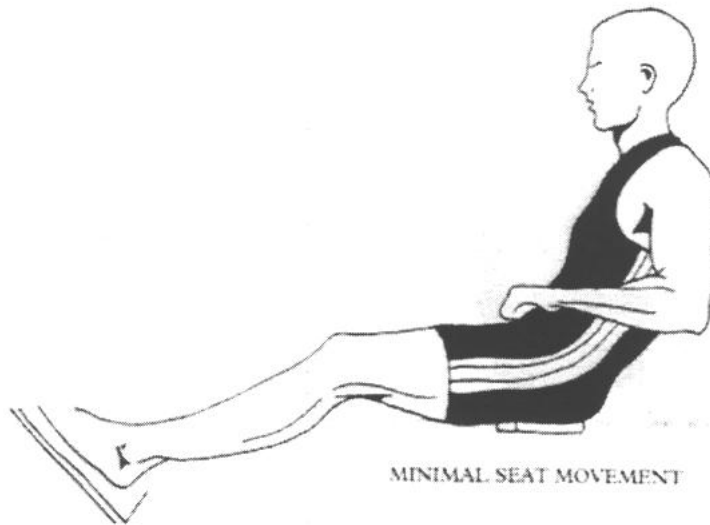

## **The Release**

The release refers to the point at which active propulsion ceases and the blades are extracted from the water.

## **Body Position at the Release**

The legs are fully extended, the back has swung past perpendicular and is at a 35-degree angle to the boat, and the chin is level with the eyes looking straight ahead. The elbows should follow the arc of the oars around at the finish ending at a point just in front of the body. Whereas, the catch motion was accomplished by raising the hands and the oar handles, the release employs a subtle downward movement of the hands in a semicircular motion. A proper visual may be created by imagining a tennis ball just in front of one's lower chest, and a release motion which comes in above the tennis ball, then down and around while avoiding contact with the body. Once the oars have left the water the wrists feather the blades to prepare for the recovery. It is vital that both blades are extracted from the water at the same time to keep the boat level and the course straight.

## **Blade Positions at the Release**

The blades should remain squared as they are extracted from the water. Once the lower edge of the blade has cleared the water the wrists should be rotated back and the blades feathered. If this is done correctly, the puddle created by the oar during the drive will appear compact and tight, with little or no white water created by the blade, as it exists.

## THE RECOVERY

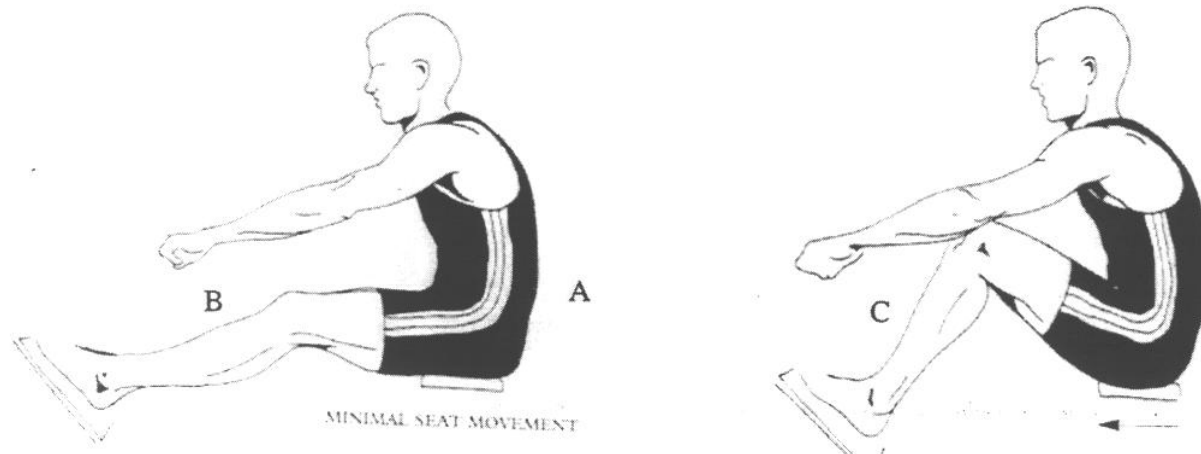

### The Recovery

The recovery is the time spent coming forward on the slide, following the release and preceding the catch.

### Body Positions During the Recovery

The sequence of body motion during the recovery is opposite that of the drive. It is important to control these motions while keeping the body weight centered over the keel of the boat. Outlined below are the three parts of the recovery in the order that they should occur.

1. Arm Extension
2. Body Forward
3. Slide Forward

#### Arm Extension:

As the blade is feathered the hands are pushed away from the body while the back remains in place- acting as a platform to aid in the extension of the arms. A one to one ratio should be maintained with the handles traveling away from the body at the same speed they came towards it. It is important to not shove the handles away or move them too slowly, as each will disturb the continuity of the recovery. As the arms come away the handles will once again overlap with the left hand above and ahead of the right.

#### Body Forward:

When the arms near full extension the back should begin to pivot forward from the hips (A). This motion forward with the back should end as the handles near the shins (B).

#### Slide Forward:

As the pivot forward nears completion, the legs begin to draw the seat toward the frontstops (C). The knees should rise slowly until the shins reach 90 degrees. If the slide forward is not controlled, the momentum of the body weight will counteract the momentum of the boat forward, acting as a brake on forward progress during the recovery. This is known as "rushing the slide."

### The Recovery Blade Position

The blades should be kept in the feathered position for the recovery. During the recovery, the blades should be kept at a uniform distance off the water with small changes when necessary to affect to set or balance of the boat. As the legs near full compression, however, the blades should be squared to prepare for the catch. When the blades are fully squared upward pressure is exerted on the handles to begin the catch motion. The blades should begin their entry with the legs just short of full compression to ensure a smooth transition from recovery to catch to drive.

## SECTION 2: NAVIGATION

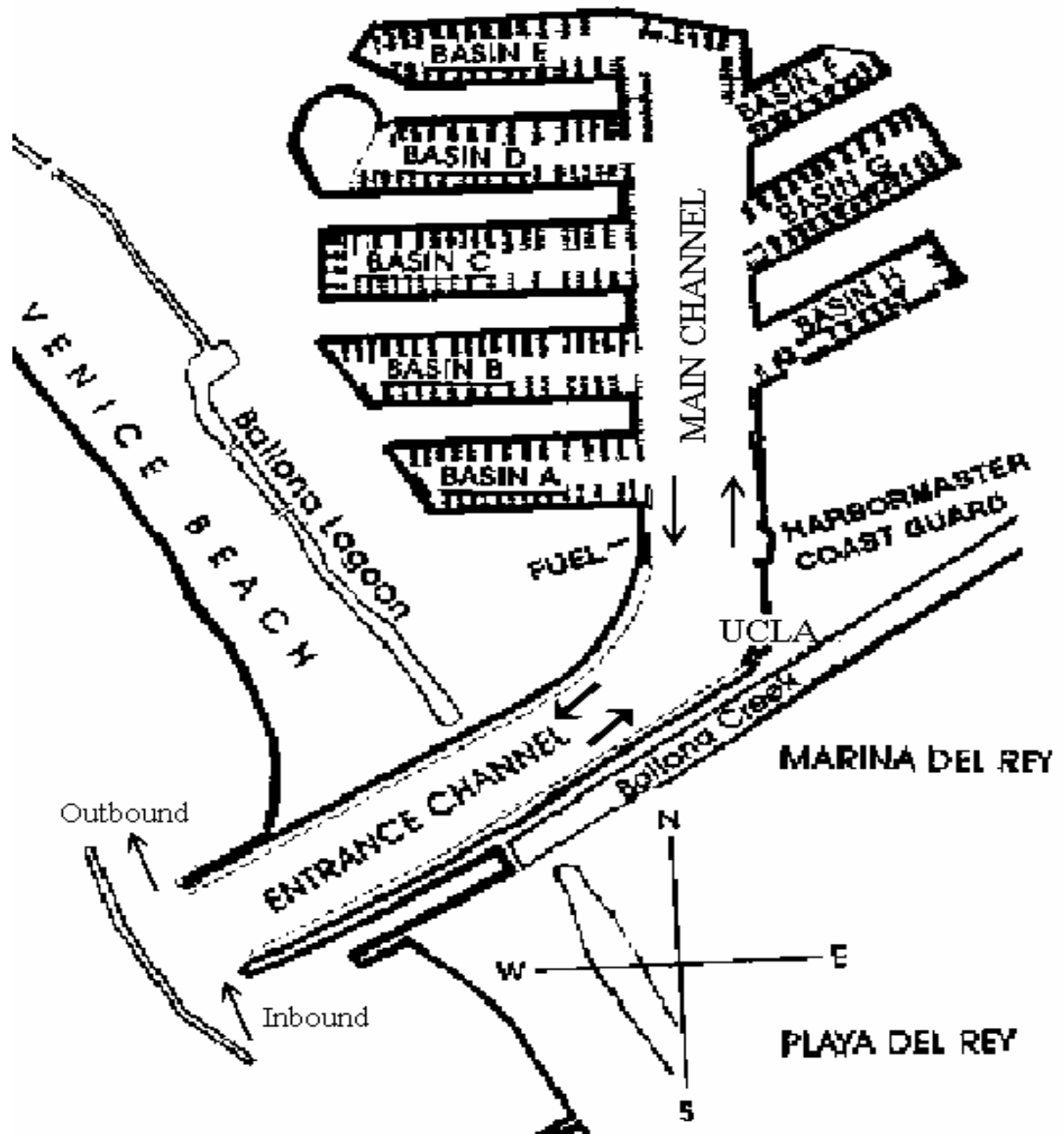

# NAVIGATING MARINA DEL REY

When rowing in Marina Del Rey, awareness is key to a safe and successful row. When rowing one must consider:

- The entire Marina and where you are in it
- Where you are relative to other boats in the Marina
- What you are doing in your own boat

## Marina Traffic Pattern and Buoys

- The traffic pattern in the Marina runs counterclockwise
  - When launching and docking at the UCLA Marina Aquatic Center it is important to honor the traffic pattern
  - This is also true when docking
- From the UCLA dock toward the break wall is considered the “Entrance Channel”
  - The center lane in between the outgoing and incoming lanes is called the Sailing Channel
    - The sailing channel is reserved for all vessels not powered by an engine. These include:
      - Sailboats
      - Rowing Shells
      - Kayaks
  - Boats under engine power are able to increase their speed in the entrance channel
    - When docking, approach from the West/Southwest area (up the entrance channel/from the breakwater)
    - It is important to keep this in consideration as you may be waked in this area
- From the UCLA dock toward the bottom of the Marina is considered the “Main Channel”
  - Faster rowing shells and rowing shells accompanied by coach boats will stay towards the buoy lines. Therefore, if you are out for a recreational row, it is safer to stay towards the center of the lane of traffic or toward the outside of the lane of traffic.
- There are several areas in the marina that are considered high traffic areas.
  - H Basin by the LMU boathouse and public launch ramp
    - The public launch ramp is located at the end of H basin. Boats will often exit this channel at high frequency especially on the weekends
  - Between D,E and F basins
    - Most rowing shells will stop and turn around at the bottom of the channel. This area is a point of high rowing shell congestion. It is important when turning to be aware of the other boats around you and to turn your boat quickly
  - UCLA Dock
    - Boats will frequently be waiting in line to dock here as well as launch. While negotiating the turn it is important to be aware of the boats around you.
- Throughout the Marina there are many buoys serving various purposes
  - Dividing directions of traffic
  - Displaying speed limit
    - Vessels exiting the Marina under engine power are able to increase their speed in the entrance channel. Once entering the main channel vessels under engine power must reduce their speed to 5 kts.
  - Marking location of smaller side channels

## Marina Right of Way and awareness

- Boats propelled by people (e.g. rowing, kayaking, paddling) are given the right of way over boats under sail or power.
  - With this in mind, it is important to consider that there are some situations in which you in a single might be more able to move than a large power boat.
  - In these situations it is important to use your best judgment. If you are unsure as to the movement of a boat larger than you, stop rowing and let the boat pass you.
- If another sculler or rowing shell is overtaking you
  - It is important to warn them of your presence.
    - This can be done by saying “heads up” or calling out the type of shell (e.g. “single”, “pair”)
  - If you are being overtaken it is important that you maintain course
    - The overtaking boat will pass you
- It is important to be aware of your surroundings
  - You should alternately look over each shoulder every 10 strokes to avoid collision
  - It is important to look out for other boats as well as standing objects
  - This will prevent the two most common causes of damage, collisions with other vessels and buoys as well as hitting the dock

**Be aware, follow the traffic pattern and have fun!**

### SECTION 3: SCULLING

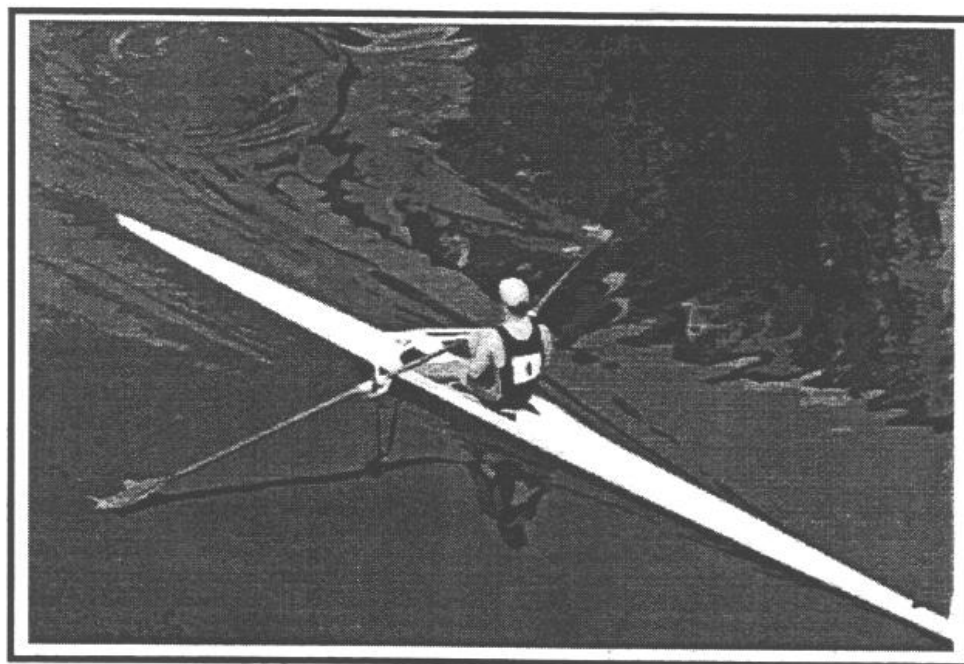

# YOUR FIRST ROW

The following information, presented in list form, outlines the procedures required to row a single rowing shell. Note that this page is not designed to serve as blueprint for every outing but rather as a set of guidelines to help you enjoy your first rowing experiences. Please pay close attention to the launching and dock procedures and always take caution when leaving or returning to the dock, as this is where most accidents happen.

## WHAT TO WEAR AND BRING TO THE BOATHOUSE

1. Tight-fitting shorts or pants (anything baggy or loose may get caught in the wheels of the seat).
2. Close-toed shoes.
3. Sweatshirt or jacket.
4. Towel and change of clothes.
5. A strap or leash for your glasses.
6. Water bottle.

## BEFORE YOU ROW

1. Jog or erg at an easy pace to prepare muscles for stretching.
2. Stretch (see section on stretching).
3. Check weather and/or rowing conditions.
4. Check-in with the dockmaster and sign out your boat.
5. Check dock for space availability.
6. Take oars down to dock.
7. Choose shell and carry down to dock with assistance from dockmaster.

## RIGGING THE SINGLE ROWING SHELL

1. Open dockside oarlock and rotate so that oarlock points towards the stern of the shell.
2. Place dockside oar in oarlock and close gate.
3. Place hand or knee closest to the dock on top of rigger so that the boat cannot lean away from the dock.
4. While facing the stern place the knee or foot closest to the water between the tracks.
5. Carefully reach out and open waterside oarlock and rotate it towards the stern of the shell.
6. Without moving your feet or knee lift the oar and place in oarlock. Close the gate on oarlock.

## GETTING INTO THE SINGLE ROWING SHELL

1. Extend waterside oar until the button of the oar rests against the oarlock.
2. Position body on bowside of rigger facing the stern.
3. Hold both grips with hand closest to the water. Lift handles so that blades are in contact with water.
4. Step into shell by placing both feet between tracks. It is important that you **ONLY** step on the area in between the tracks. This is the only part of the boat that can withstand your body weight. **DO NOT** step on the deck, on the footstretchers or on the bottom of the boat.
5. Sit down on seat.

## LAUNCHING FROM THE DOCK

1. Hold both oars with the hand closest to the water and push legs flat.
2. Lower hands and lean body away from dock so that oar and rigger do not drag.
3. Push away from dock with hand closest to the dock.

## RETURNING TO THE DOCK

1. Approach the dock from the breakwater side of the marina. Your course should parallel the dock.
2. Within 25 yards of the dock reduce speed by rowing with the arms and back only. Begin looking behind you and adjusting course as necessary to approach dock.
3. Raise the oar closest to the dock off the water by pushing handles down and leaning away.
4. Maintain this position until close enough to grab the dock.

# SCULLING EQUIPMENT

## SINGLE ROWING SHELL

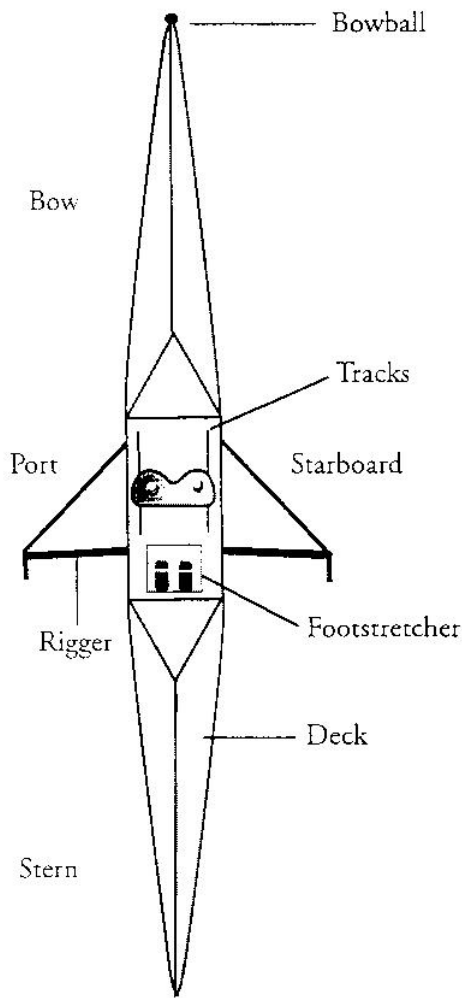

## PARTS OF THE BOAT

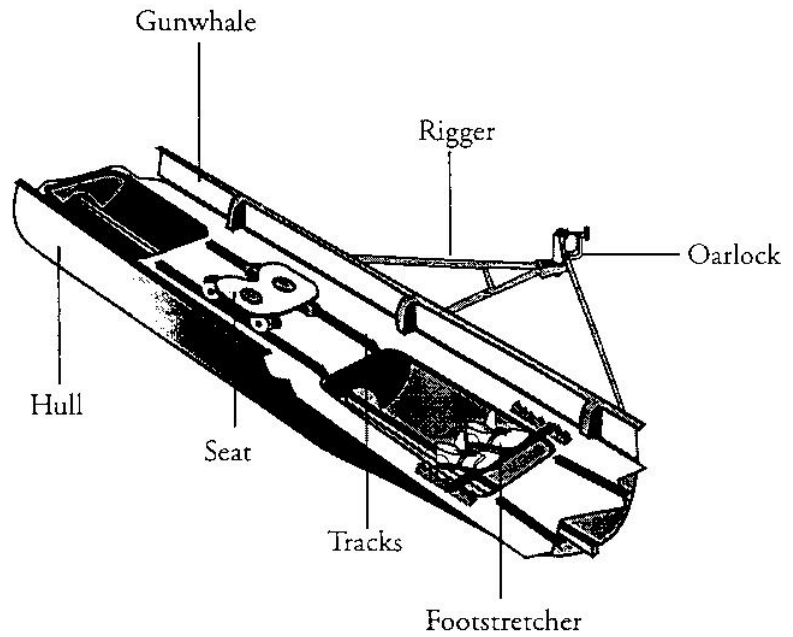

## THE RIGGER

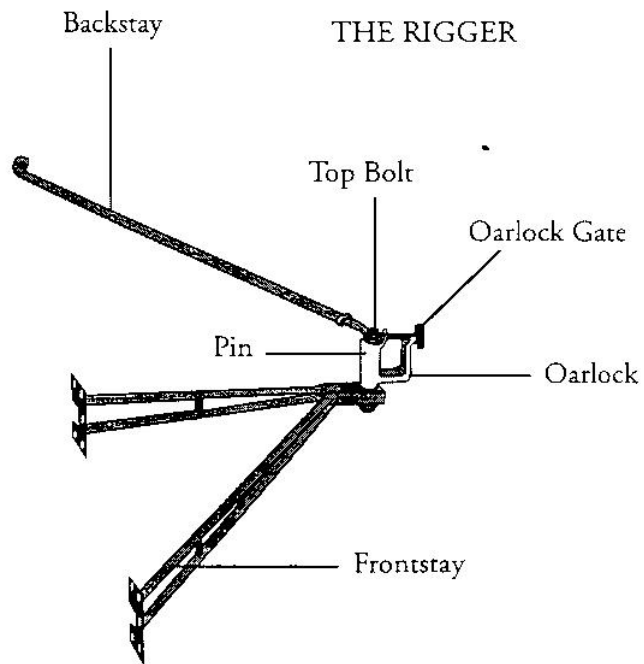

## THE OAR

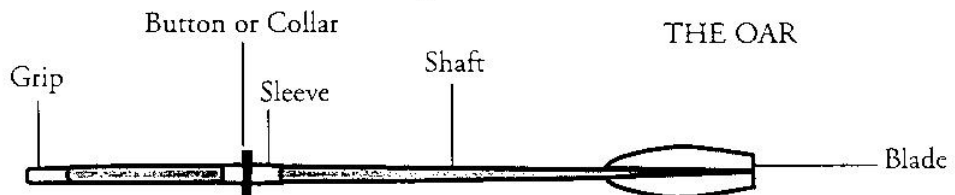

Note that sculling oar is shorter and smaller than sweep oar

# SCULLING: EQUIPMENT CARE AND HANDLING

## OARS

1. Carry and place oars on the dock tips up.
2. Never stand oars against building.
3. Do not drag blades on the dock while docking or launching. Do not drag grips on the ground. The grips must stay off the ground at all times.
4. Rinse and wipe oars down thoroughly after each use. When rinsing the oars, rest the oars in the boat slings with the blades on the ground and the grips off the ground.
5. When placing oars in rack do not stack the buttons on top of each other, as this will cause the oars to fall.

## SHELLS

1. While carrying boats, dockmasters and users/renters are responsible for preventing riggers and/or boat from hitting other objects. Communicate with the individual you are carrying the boat with so that the equipment is not damaged.
2. When placing shell in water, users need to push boat away from the dock to ensure skeg is not damaged.
3. Scullers are responsible for holding the shell off the dock to prevent rubbing due to waves and/or wakes.
4. Wash and dry boats on both sides. Specifically, all metal parts as these will easily rust.

## MISC. EQUIPMENT

1. Ergs should be properly stored after use.
2. Wipe ergs with clean towel after workout.

## LIGHTS

1. All shells out before sunrise or after sunset must use lights.
2. Red and green lights are for bow and white lights are for stern.
3. Attach lights in boathouse not on the dock.
4. The dockmaster will provide lights to renters. They are color coded with tape to identify whom they belong to.  
Blue- UCLA Collegiate    Red- Juniors                      Rental-Yellow

## REPAIR

1. Boats in need of repair should be stored upright in slings and reported to dockmaster.
2. Users should not swap equipment between boats. Rowers should not adjust rigging or boats or oars at any time.
3. Rowers should check equipment before each row.
4. Give any broken equipment to dockmaster.

## SLINGS

1. Rolling slings should be pushed to the sides of boathouse, out of the way of traffic.
2. When storing folding slings, ensure that fabric is not pinched or scissored between the arms of the sling.
3. When moving boats in rolling slings, always hold the boat and the sling.

# BLADEWORK

Bladework is a term used to describe the actions a rower takes to control the movement of the oar during the stroke cycle. As a beginning or developing rower it is very important to understand and master bladework as it plays a large role in determining the speed and stability of the rowing shell. In fact, perhaps the single greatest deterrent to boat speed is a lack of catch timing. Similarly a lack of release timing or uniform blade height will play havoc with the stability of the boat.

## BLADE POSITIONS

Before getting into the specifics of bladework it is first necessary to define the various blade positions and the hand positions used to obtain them. There are two primary blade positions - square and feathered. A squared blade is used during the drive (see diagram below) to propel the boat through the water. A feathered blade is employed during the recovery (see diagram below), and its flat position allows for the blade to rest on top of the water.

FIG. A: SQUARED BLADE

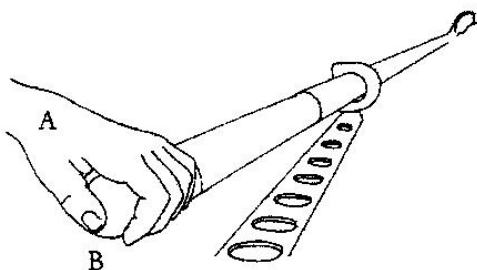
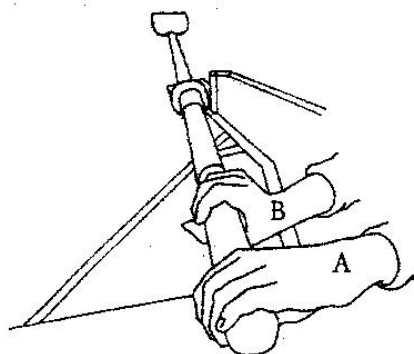

FIG. B: FEATHERED BLADE



## HAND POSITIONS – SCULLING

In sculling, as shown in figure A, the oars are held in both hands. When the blade is square and the oar is being pulled through the water, the hand should be positioned such that the wrists stay flat, with no flex in either direction (A). The oar handles should be gripped as loosely as possible with the hands acting like hooks to pull the oars, and the thumbs pressed against the ends of the grips to keep the oars from pulling out of the oarlocks (B). To maximize your leverage, keep the hands about 1-2 inches from the ends of the oars.

To change the oar to the feathered position, as you will do at the finish of each stroke, one gives a relaxed turn to the grip. Drop the wrist slightly while rolling the top of the grip towards the chest, while at the same time letting the grip roll out more under the fingers. To move the blade back to the squared position, squeeze the fingers toward the palm and rotate the wrist away from the body until it is flat.

## SCULLING: DIFFERENCES

Although the fundamentals of sculling are quite similar to those of sweep rowing, it is possible to draw some important technical distinctions between the two disciplines. These differences, illustrated below, are centered around the fact that scullers must handle two oars while sweep rowers only one.

### DIFFERENCE ONE: THE GRIP/BLADEWORK

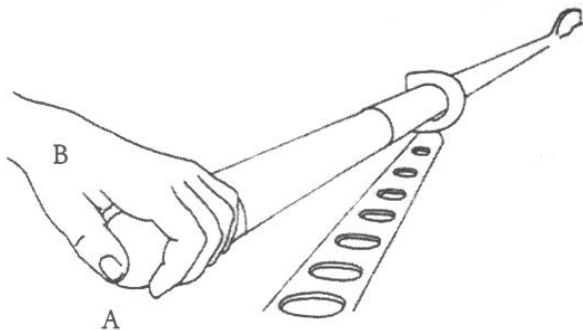

The handling of two oars simultaneously necessitates technique adaptations. Each hand holds an oar on the grip with the thumb pressed against the end of the oar to keep the button firmly pressed against the oarlock (A). When the blade is squared the wrists should be kept flat and the fingers relaxed (B). During the drive the hands should function like hooks, with care taken not to over grip the handles. The wrists are then pulled back to feather the blades.

### DIFFERENCE TWO: THE ARC

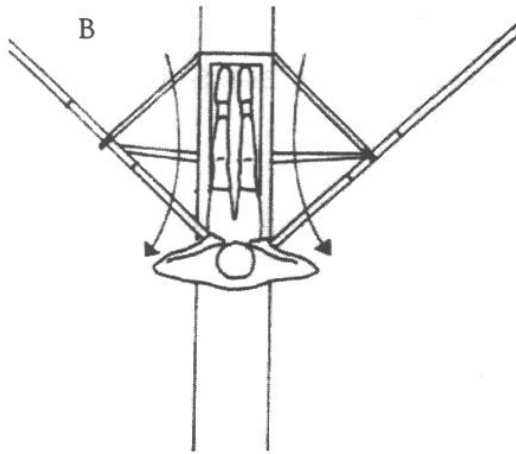
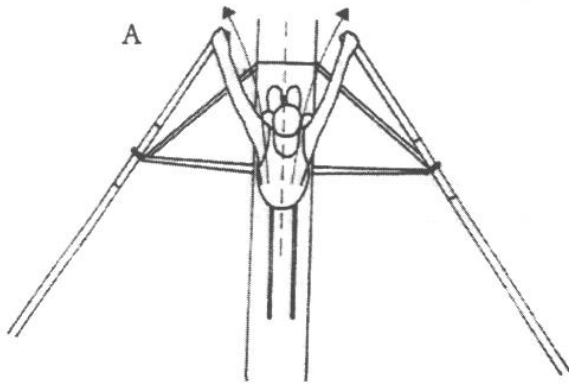

In sweep rowing the rower moves his or her body within the arc of the oar, but in sculling the hands and arms are used to follow the arc. The body stays centered over the keel of the boat while the hands travel through the arcs. At the catch the hands come apart and travel out towards the gunwales again, before being stopped just in front of the rowers chest. It is important to remember that extra length is obtained when the oars are allowed to move further through their arc while the body remains centered. Do not attempt to gain more length by using the body.

## SCULLING: TECHNIQUE FAULTS

Below are some technical problems common to sculling as well as what drills can be done to address them. They are divided into the parts of the stroke that they occur.

### THE CATCH

<u>Fault</u>	<u>Symptom</u>	<u>Cause</u>	<u>Solution/Drill</u>
Missing Water	Blades not in water as drive begins.	<ol style="list-style-type: none"> <li>1. Blades not squared as drive begins.</li> <li>2. Slow catch motion.</li> </ol>	<ol style="list-style-type: none"> <li>1. Rollup as handles pass over ankles.</li> <li>2. Begin catch motion before end of recovery.</li> <li>3. Balance Drills &amp; Legs Only Drill</li> </ol>
Blade Goes Deep	Blades buried well below surface.	<ol style="list-style-type: none"> <li>1. Blades undersquared.</li> <li>2. Catch motion performed with too much upper body motion.</li> <li>3. Oar handles lifted too high at catch.</li> </ol>	<ol style="list-style-type: none"> <li>1. Practice squaring and feathering.</li> <li>2. Do not lift upper body at catch, only outside hand is lifted.</li> <li>3. Practice burying ½ of the blade.</li> <li>4. ½ Leg Drive Drill</li> </ol>
Blades Skying	Blades too high off the water at catch.	<ol style="list-style-type: none"> <li>1. Handles are lowered before being raised.</li> <li>2. Outside shoulder too low.</li> </ol>	<ol style="list-style-type: none"> <li>1. Row with oars on top of water.</li> </ol>
Boat Unset	Boat leans to one side at catch.	<ol style="list-style-type: none"> <li>1. Hands are not lifted together.</li> </ol>	<ol style="list-style-type: none"> <li>1. Legs Only Drill</li> </ol>
Short Stroke	Rower never reaches full slide.	<ol style="list-style-type: none"> <li>1. Apprehensive of reaching full slide where boat is least stable.</li> </ol>	<ol style="list-style-type: none"> <li>1. Shadow rowing with blades on top of water.</li> </ol>

### THE DRIVE

Slide Shooting	Seat moves faster than oar handles during leg drive.	<ol style="list-style-type: none"> <li>1. Poor low back support.</li> </ol>	<ol style="list-style-type: none"> <li>1. Sit tall and support lower back.</li> <li>2. Legs Only Drill</li> </ol>
Early Backswing	Backswing begins too early.	<ol style="list-style-type: none"> <li>1. Not enough forward body angle.</li> <li>2. Leg drive too weak.</li> <li>3. Body is set forward too late on recovery.</li> </ol>	<ol style="list-style-type: none"> <li>1. Emphasize leg drive.</li> <li>2. Legs Only Drill</li> <li>3. Body Set Pause Drill</li> </ol>
Blade Too Deep	Shaft buried during drive.	<ol style="list-style-type: none"> <li>1. Hands too high during drive.</li> </ol>	<ol style="list-style-type: none"> <li>1. Bring handles towards body in level path.</li> <li>2. ½ Blades Buried Drill.</li> </ol>
Right-Side Lean	Boat leans to right during entire stroke cycle.	<ol style="list-style-type: none"> <li>1. Hands are kept too far apart to avoid hitting.</li> <li>2. Right handle too low.</li> </ol>	<ol style="list-style-type: none"> <li>1. Row with blades on top of water with hands together.</li> </ol>

## SCULLING: TECHNIQUE FAULTS

Below are some technical problems common to sculling as well as what drills can be done to address them. They are divided into the parts of the stroke that they occur.

### THE FINISH

<u>Fault</u>	<u>Symptom</u>	<u>Cause</u>	<u>Solution/Drill</u>
Washing Out	Blades rising out of the water too early.	<ol style="list-style-type: none"> <li>1. Hands drawn to waist not to chest.</li> <li>2. Elbows too low.</li> </ol>	<ol style="list-style-type: none"> <li>1. Blade should stay buried through finish.</li> </ol>
Dirty Finish	Not able to release blade from water.	<ol style="list-style-type: none"> <li>1. Blade too deep.</li> <li>2. Feathering while blade is underneath the water.</li> </ol>	<ol style="list-style-type: none"> <li>1. ½ Blade Buried Drill</li> <li>2. Square Blade Rowing</li> <li>3. Delayed Feather Drill</li> </ol>
Short Stroke	Elbows never cross through the plane of the body.	<ol style="list-style-type: none"> <li>1. Improper foot stretcher placement.</li> <li>2. Blade is extracted too early.</li> </ol>	<ol style="list-style-type: none"> <li>1. See YOUR FIRST ROW- on foot stretcher placement.</li> <li>2. Arms Only Drill</li> </ol>
Oars Pulled Away	Button does not remain against oarlock at finish.	<ol style="list-style-type: none"> <li>1. Thumbs are not pressed against end of oar.</li> </ol>	<ol style="list-style-type: none"> <li>1. Arms Only Drill with thumbs against the end of the oar.</li> </ol>

### THE RECOVERY

Rushing The Slide	Hanging at catch waiting for other rowers/ Boat feels heavy during drive.	<ol style="list-style-type: none"> <li>1. Legs rise too quickly during recovery.</li> <li>2. Hands are too slow away from body.</li> </ol>	<ol style="list-style-type: none"> <li>1. Count Drill</li> <li>2. Pause Drills</li> <li>3. Keep hands moving away from body in smooth, continuous motion.</li> </ol>
Lunging	Too much forward body angle.	<ol style="list-style-type: none"> <li>1. Body is not set forward properly.</li> </ol>	<ol style="list-style-type: none"> <li>1. Body angle should be fixed once legs begin to move up.</li> <li>2. Body Set Pause Drill</li> </ol>
Poor Balance	Boat dips from one side to the other.	<ol style="list-style-type: none"> <li>1. Body is not centered.</li> <li>2. Handles are not carried correctly.</li> </ol>	<ol style="list-style-type: none"> <li>1. Center body over keel.</li> <li>2. Pause and Glide Drills</li> <li>3. Shadow Rowing Drill</li> </ol>

## SCULLING: CAPSIZE RECOVERY

It is possible to either fall out of or capsize a single rowing shell. In fact, most rowers will encounter this problem multiple times during their rowing careers. As a result, Outdoor Adventures requires that all renters properly demonstrate the ability to safely enter a single rowing shell from the water. This must be done during the second class of Sculling I or in the Skills Evaluation/Orientation session prior to receiving rental certification.

The procedure outlined below is designed around righting and entering an open water rowing shell. These boats are heavy-duty and are sturdy enough to withstand the forces involved with re-entering. A lightweight racing shell, on the other hand, is quite fragile and may sustain damage to the gunwales and/or splashbox during this type of maneuver.

### PROCEDURE FOR WET-ENTRY

1. Right the shell if necessary (it is often not) by pressing down on the rigger nearest you, and as the shell turns up on its side, reach up and pull the upper edge or rigger toward you. If it is very windy, you must either point the bow or stern into the wind to make the boat more manageable. Please take caution as the boat begins to turn over as the oars can strike you in the head.
2. Position yourself on the bow side of the rigger, facing the seat deck.
3. Place the oar on your side of the shell perpendicular to the boat with the blade feathered. Hold onto that oar handle with the hand nearest it; your hand, with the oar in it, will press down against the seat deck.
4. Push your body up on the shell using the oar nearest you for support until you are far enough across the shell to reach the oar on the far side.
5. Facing the seat deck, hold both handles in the hand closest to the rigger. Using the oars as support, by pressing the handle down against the seat deck, lift your torso up onto the boat by kicking your legs and performing a "pushup" type motion. Resist the temptation to pull on the far edge of the boat, as this will cause the boat to roll over again.
6. Once your torso is on top of the boat, swing your legs towards the bow and straddle the boat. Alternatively you can swing your legs towards the rigger so that you sit in a sidesaddle position. Either way is correct if it feels easier and more natural.
7. Raise the oar handles so that the blades are against the water.
8. Swing your legs into the boat.
9. Using the hand that is not on the oars, lift your body onto the seat by pressing between the tracks.
10. The Baycraft rowing shells used at the UCLA Marina Aquatic Center are equipped with a bailing device. To operate it simply pull up on the lever and push the chute down. The boat must be in motion for draining to occur.
11. All of the single rowing shells used at the UCLA Marina Aquatic Center may be rowed with the cockpit full of water. The ends of the rowing shells are airtight and will keep the shell afloat provided they have not been punctured.

## SECTION 4: SWEEP ROWING



# YOUR FIRST ROW

The following information, presented in list form, outlines the procedures required to row in a sweep rowing shell. Note that this page is not designed to serve as a blueprint for every outing, but rather as a set of guidelines to help you enjoy your first sweep rowing experiences. Please pay attention to the fact that in many sweep boats the coxswain determines the order of many of the items listed below. In boats without a coxswain the bowperson serves as the leader and will give commands serves as the leader and will give commands for the other rowers to follow.

## WHAT TO WEAR AND BRING TO THE BOATHOUSE

1. Tight-fitting shorts or pants (anything loose or baggy may get caught in the wheels of the seat).
2. Close-toes shoes
3. Sweatshirt or jacket
4. Towel and change of clothes
5. A strap or leash for your glasses
6. Water Bottle

## BEFORE YOU ROW

1. Jog or erg at an easy pace to prepare for stretching
2. Stretch (see appendix A)
3. Check weather and/or rowing conditions
4. Determine lineup or order of rowers in boat (often done by coach or coxswain).
5. Bring oars down to dock.
6. Check dock for space availability.
7. Choose shell and carry down with assistance from teammates.

## RIGGING A SWEEP ROWING SHELL

1. Open oarlock gate and rotate so that oarlock points toward the stern of the boat.
2. For waterside oars, place knee or foot between tracks and reach out and open oarlock.
3. Place oar in oarlock and close gate (do not extend oar).

## GETTING INTO THE SWEEP ROWING SHELL

1. Extend waterside oars until the buttons of the oars rest against the oarlocks.
2. Position body next to designated seat facing the stern.
3. Hold handle with hand closest to water.
4. Step into shell by placing both feet between the tracks (do not step down onto the hull of the boat).
5. Stagger feet and sit down on seat.
6. Adjust footstretchers so that at full slide catch position wheels are 2 inches from the frontstops.

## LAUNCHING FROM THE DOCK

1. Hold oar with hand closest to the water. Push legs flat.
2. When coxswain or bowperson gives command, lean away from the dock.
3. When coxswain or bowperson gives command, push away from the dock.

## RETURNING TO THE DOCK

1. Keep talking to a minimum, as you will need to hear coxswain's or bowperson's commands.
2. As boat nears dock, when command is given, lean away from the dock.
3. Raise the dockside oars off the water and away from the dock.
4. Hold the oar with the waterside hand and reach for dock with the dockside hand.

## **SWEEP ROWING EQUIPMENT**



# EIGHT PERSON ROWING SHELL

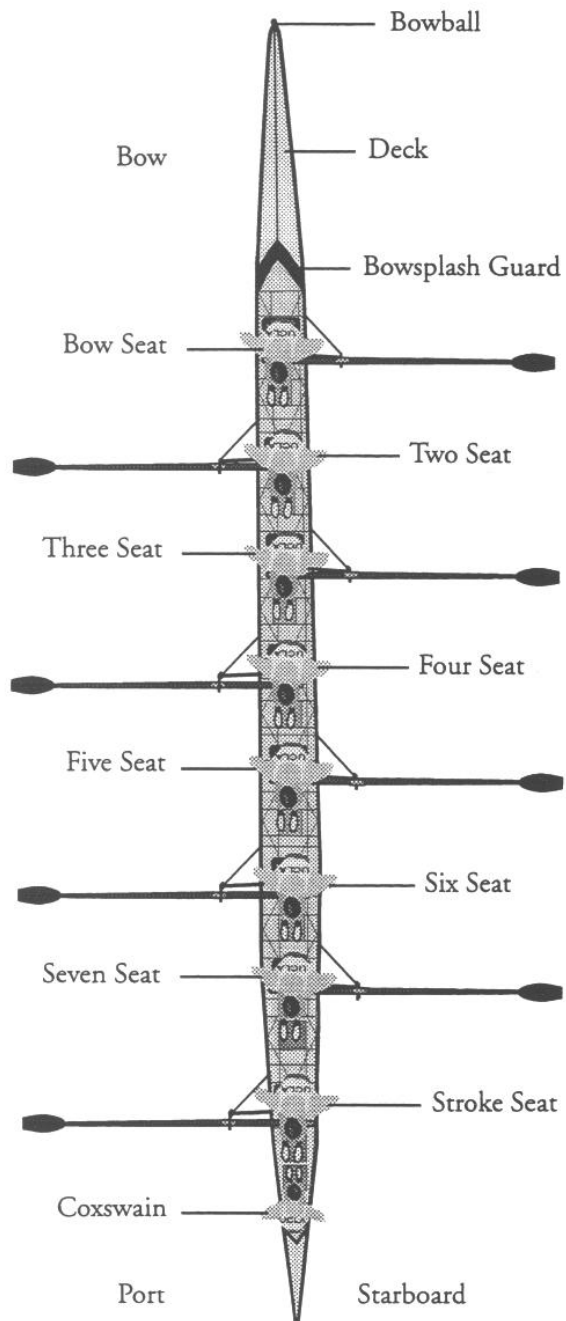

## PARTS OF THE BOAT

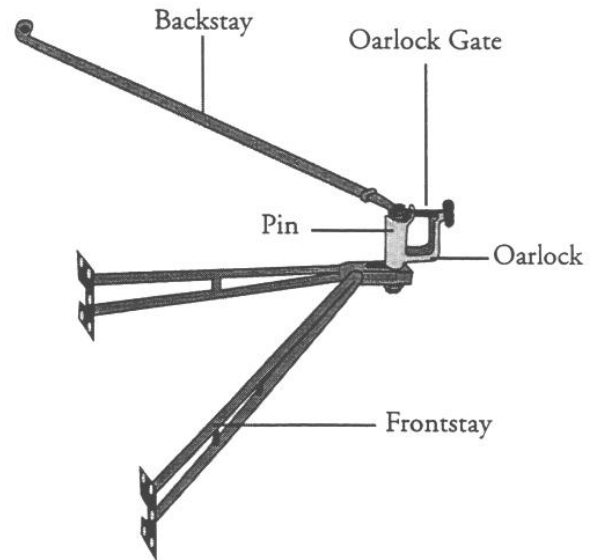
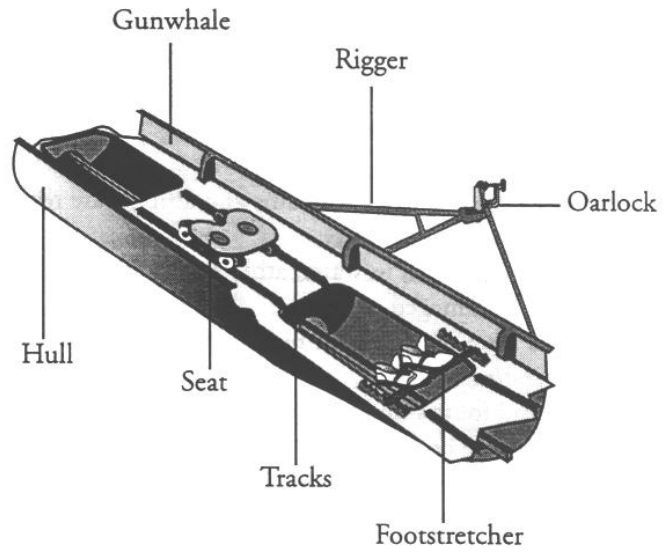

## THE RIGGER

## THE OAR

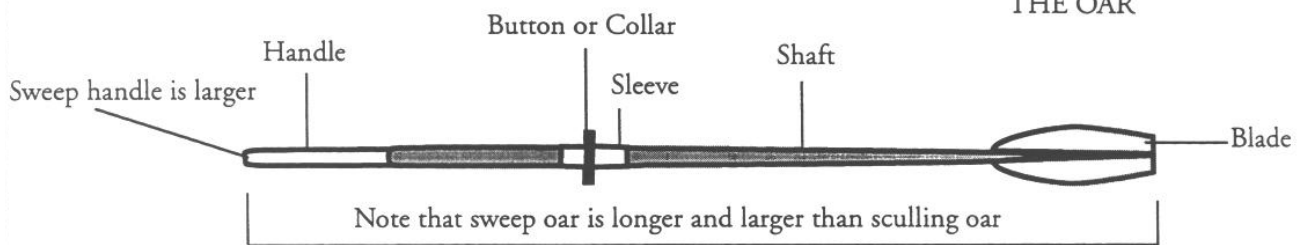

# **SWEEP ROWING: EQUIPMENT CARE AND HANDLING**

## **OARS**

1. Carry and place the oars on the dock tips up.
2. Never stand oars against building.
3. Do not drag blades on the dock while docking or launching.
4. Rinse and wipe oars down thoroughly after each use.
5. When placing oars in rack do not leave handles in cup.

## **SHELLS**

1. While carrying boats, coxswains and athletes are responsible for preventing riggers and/or boat from hitting other objects.
2. When placing shell in water, athletes need to push boat away from dock to ensure skeg is not damaged.
3. Athletes are responsible for holding the shell off the dock to prevent rubbing due to waves and/or wakes.
4. Eights and fours should be stored in boathouse sterns first.
5. When storing boats on floor ensure that riggers and pins are not touching the floor.
6. Wash and dry boats on both sides.
7. Never step over a boat on the floor, always walk around it.

## **MISC. EQUIPMENT**

1. Ergs should be properly stored after use.
2. Wipe ergs with clean towel after workout.

## **LIGHTS**

1. All shells out before sunrise or after sunset must use lights.
2. Red and green lights are for bow and white lights are for stern.
3. Attach lights in boathouse, not on the dock.
4. Lights are color coded with tape to identify which team they belong to.  
Blue- UCLA Collegiate Red- Juniors
5. When placing lights in locker make sure they are in correct locker, with batteries in "RECHARGE" box, and lenses reattached to body of light.

## **REPAIR**

1. Boats in need of repair should be stored upright in slings and reported to coach or boat captain.
2. Athletes should not swap equipment between boats.
3. Coaches and boat captains are responsible for filling out repair requests.
4. Rowers should check equipment for tightness and breakage.

## **SLINGS**

1. Rolling slings should be pushed to the sides of boathouse, out of the way of traffic.
2. When storing folding slings, ensure that fabric is not pinched or scissored between the arms of the sling.
3. When moving boats in rolling slings, always hold both the boat and the sling.

# BLADEWORK

Bladework is a term used to describe the actions a rower takes to control the movement of the oar during the stroke cycle. As a beginning or developing rower it is very important to and master bladework as it plays a large role in determining the speed and stability of the rowing shell. In fact, perhaps the single greatest deterrent to boat speed is a lack of catch timing. Similarly a lack of release timing or uniform blade height will play havoc with the stability of the boat.

## BLADE POSITIONS

Before getting into the specifics of bladework it is first necessary to define the various blade positions and the hand positions used to obtain them. There are two primary blade positions- square and feathered. A squared blade is used during the drive (see diagram below) to propel the boat through the water. A feathered blade is employed during the recovery (see diagram below), and its flat position allows for the blade to slide along the water.

FIG. A: SQUARED BLADE

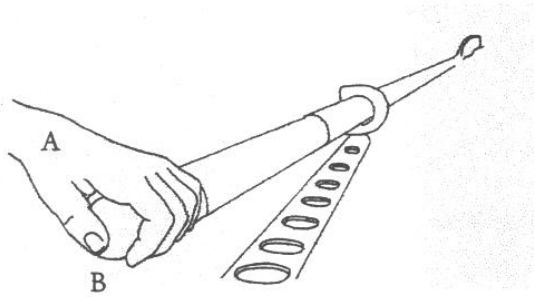
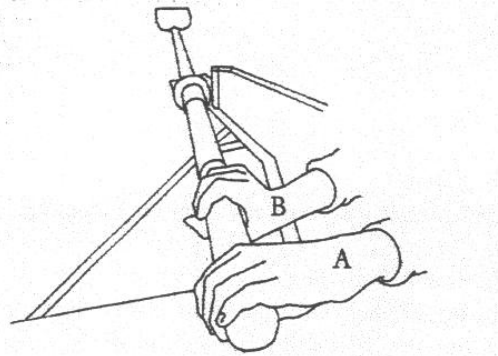

FIG. B: FEATHERED BLADE



## HAND POSITIONS- SWEEP ROWING

In sweep rowing, as shown in figure B, the oar is held with both hands. When the blade is square and the oar is being pulled through the water, the hands should be positioned about 6-12 inches apart, with the wrists as flat as possible. During the drive, the pulling action is performed primarily with the outside hand (the hand furthest from the blade) because of its greater leverage relative to the inside hand. The outside wrist, as a result, is always kept flat (A). All of the squaring and feathering motions are performed with the inside wrist.

To change the oar to the feathered position twist the oar with the inside hand so that handle is rotated toward the chest (B). The outside hand should loosely grip the oar to the extent that the handle smoothly turns within it, allowing the outside wrist to remain flat. To square the oar the inside wrist is returned to its original flat position.

## SWEEP ROWING: DIFFERENCES

Although the fundamentals of sweep rowing are quite similar to those of sculling, it is possible to draw some important technical distinctions between the two disciplines. These differences, illustrated below, are centered around the fact that sweep rowers have one oar while scullers have two.

### DIFFERENCE ONE: THE GRIP/BLADEWORK

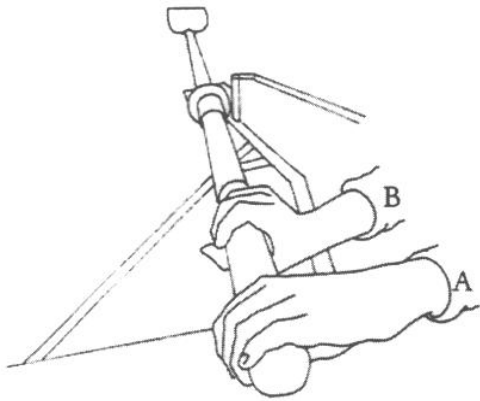

In sweep rowing, both hands are used to control the single oar. The outside arm (A), the arm furthest from the blade, is used for pulling. Due to its relative leverage, the outside arm does most of the actual work. Because its primary focus is to provide strength, the outside wrist should be kept flat throughout the stroke cycle. The outside arm is also used for the catch and extraction motions. The inside arm is used to control the orientation of the blade. By moving the wrist either forward or backward (B) the blade may be moved between the squared and feathered positions.

### DIFFERENCE TWO: THE ARC

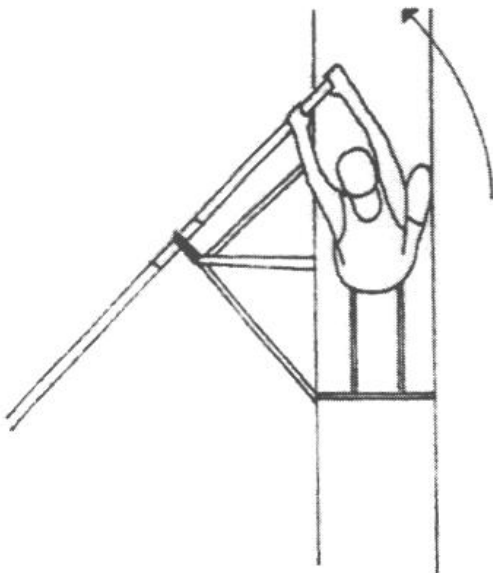

In sweep rowing, the torso follows the arc of the oar at the catch and at the finish. This allows for a longer stroke, as the rower is able to follow the oar's movements. To facilitate the movement of the body within the arc, the inside shoulder is relaxed and kept slightly lower than the outside, while the inside arm is bent at the elbow. The inside shoulder should be relaxed and lower than the outside throughout the entire cycle. To maintain a smooth stroke thing abut following the arc throughout the entire motion instead of just at the catch and finish. In other words, do not lunge into the arc at the catch or fall into it at the finish.

# SWEEP ROWING: TECHNIQUE FAULTS

Below are some technical problems common to sweep rowing as well as what drills can be done to address them. They are divided into the parts of the stroke that they occur.

## THE CATCH

<u>Fault</u>	<u>Symptom</u>	<u>Cause</u>	<u>Solution/Drill</u>
Missing Water	Blades not in water as drive begins.	<ol style="list-style-type: none"> <li>1. Blades not squared as drive begins.</li> <li>2. Slow catch motion.</li> </ol>	<ol style="list-style-type: none"> <li>1. Rollup as handles pass over ankles.</li> <li>2. Begin catch motion before end of recovery.</li> <li>3. Balance Drills &amp; Legs Only Drill</li> </ol>
Blade Goes Deep	Blades buried well below surface.	<ol style="list-style-type: none"> <li>1. Blades undersquared.</li> <li>2. Catch motion performed with too much upper body motion.</li> <li>3. Oar handles lifted too high at catch.</li> </ol>	<ol style="list-style-type: none"> <li>1. Practice squaring and feathering.</li> <li>2. Do not lift upper body at catch, only outside hand is lifted.</li> <li>3. Practice burying ½ of the blade.</li> <li>4. ½ Leg Drive Drill</li> </ol>
Excessive Reach Forward	Outside shoulder too low.	<ol style="list-style-type: none"> <li>1. An attempt to get length by stretching forward.</li> </ol>	<ol style="list-style-type: none"> <li>1. Wide Grip-Legs Only Drill</li> </ol>
Blades Skying	Blades too high off the water at catch.	<ol style="list-style-type: none"> <li>1. Handles are lowered before being raised.</li> <li>2. Outside shoulder too low.</li> </ol>	<ol style="list-style-type: none"> <li>1. Row with oars on top of water.</li> </ol>

## THE DRIVE

Slide Shooting	Seat moves faster than oar handles during leg drive.	<ol style="list-style-type: none"> <li>1. Poor low back support.</li> </ol>	<ol style="list-style-type: none"> <li>1. Sit tall and support lower back.</li> <li>2. Legs Only Drill</li> </ol>
Early Backswing	Backswing begins too early relative to other rowers.	<ol style="list-style-type: none"> <li>1. Not enough forward body angle.</li> <li>2. Leg drive too weak.</li> <li>3. Body is set forward too late on recovery.</li> </ol>	<ol style="list-style-type: none"> <li>1. Emphasize leg drive.</li> <li>2. Legs Only Drill</li> <li>3. Body Set Pause Drill</li> </ol>
Blade Too Deep	Shaft buried during drive.	<ol style="list-style-type: none"> <li>1. Hands too high during drive.</li> </ol>	<ol style="list-style-type: none"> <li>1. Bring handles towards body in level path.</li> <li>2. ½ Blades Buried Drill.</li> </ol>
Leaning Away	Body leans away from rigger during drive.	<ol style="list-style-type: none"> <li>1. Inside shoulder higher than the outside.</li> <li>2. Weight not over center.</li> </ol>	<ol style="list-style-type: none"> <li>1. Wide Grip Drill</li> </ol>
Gaffing	Rower in front is hit by your oar handle.	<ol style="list-style-type: none"> <li>1. Catch is too slow.</li> <li>2. Drive is not connected.</li> </ol>	<ol style="list-style-type: none"> <li>1. Legs Only Drill</li> <li>2. See Slide Shooting</li> </ol>

# SWEEP ROWING: TECHNIQUE FAULTS

Below are some technical problems common to sculling as well as what drills can be done to address them. They are divided into the parts of the stroke that they occur.

## THE FINISH

<u>Fault</u>	<u>Symptom</u>	<u>Cause</u>	<u>Solution/Drill</u>
Washing Out	Blades rising out of the water too early.	<ol style="list-style-type: none"> <li>1. Hands drawn to waist not to chest.</li> <li>2. Leaning away from rigger at finish.</li> <li>3. Outside elbow too low.</li> </ol>	<ol style="list-style-type: none"> <li>1. Blade should stay buried through finish.</li> <li>2. Wide Grip-Arms Only Drill</li> </ol>
Dirty Finish	Not able to release blade from water.	<ol style="list-style-type: none"> <li>1. Blade too deep.</li> <li>2. Feathering while blade is underneath the water.</li> </ol>	<ol style="list-style-type: none"> <li>1. ½ Blade Buried Drill</li> <li>2. Square Blade Rowing</li> <li>3. Delayed Feather Drill</li> </ol>

## THE RECOVERY

Rushing The Slide	Hanging at catch waiting for other rowers/ Boat feels heavy during drive.	<ol style="list-style-type: none"> <li>1. Legs rise too quickly during recovery.</li> </ol>	<ol style="list-style-type: none"> <li>1. Count Drill</li> <li>2. Pause Drills</li> </ol>
Lunging	Too much forward body angle.	<ol style="list-style-type: none"> <li>1. Body is not set forward properly.</li> </ol>	<ol style="list-style-type: none"> <li>1. Body angle should be fixed once legs begin to move up.</li> <li>2. Body Set Pause Drill</li> </ol>

## **SWEEP ROWING: THE ROLE OF THE COXSWAIN**

As previously mentioned, some sweep rowing shells, eights, fours, and some pairs, are built to include a seat for a coxswain. Depending on how the boat is made, the coxswain either sits facing the stroke seat rower or is just ahead of the bow seat facing the bow of the boat. Coxswains are a very important part of any crew, performing a multitude of tasks over the course of a practice or race. In addition to steering the shell, the coxswain's duties include instructing the rowers on proper technique, timing the workouts, motivating the rowers, while also making strategic decisions during races. It is important that all rowers respect the role of the coxswain as well as the complexity of the tasks they are asked to perform. If it is physically possible all rowers should try coxing in order to see rowing from a different perspective.



### **COMMANDING A CREW**

The coxswain should always be in full control of the boat. Confusion results when a coxswain permits the rowers to make decisions or act unilaterally. Rowers can give advice or talk to each other but only when the coxswain allows them to do so. To gain the respect of the rowers the coxswain should always take command and appear confident and competent regardless of whether or not this is actually the case. The commands, when given, should be in three parts: a description of the action to be performed a "ready" command and an action command. Some common commands are listed on the following page.

### **STEERING**

Every boat will steer differently depending on the size and shape of the shell, the size and shape of the rudder, the weather conditions, and the relative strength of the rowers. As a result, steering a straight course can be extremely difficult for the novice coxswain. It is important to remember that moving the rudder in any direction creates drag and makes the boat unstable. As a result, all steering should come in increments and be done only when the rowers are in the drive phase of the stroke. This requires the coxswain to anticipate necessary course corrections well in advance of when they should be made. If this is not done then it becomes very difficult to correct course without a major turn of the rudder.

### **SAFETY**

The coxswain, above all else, is responsible for the safety of the rowers and the equipment. Primarily this involves watching for obstacle like buoys, other boats, and docking and launching safely. If a coxswain is unsure of whether or not he is going to hit something, then the proper response is to err on the side of caution and stop. It is far better to sacrifice part of a workout than damage a boat or injure a rower. Coxswains should always exercise caution when approaching the dock. The shells are fragile and are easily damaged when the boat is improperly docked.

# **SWEEP ROWING: COXSWAIN COMMANDS**

The commands below are to be used when coxing an eight-oared shell; if coxing a smaller boat, simply substitute “four” into every “all eight” command.

## **LIFTING AN EIGHT OFF THE RACK**

1. “All eight hands on” or “all eight lay hold” (it is necessary to have four rowers on each side)
2. “Ready to lift off the rack” (always describe the action to be done before giving action command)
3. “Watching the boat above...Ready and lift!”
4. “All eight sidestep the boat out from the rack.”
5. Depending on what rack the boat is stored on you may have to tell the rowers to put the boat on their shoulders.

## **WALKING AN EIGHT TO THE DOCK**

1. “All eight walk it down- watch riggers on the boathouse.” (Coxswain walks with his/her hand on the stern)
2. “Bow/Stern swing left/right” (tell rowers which way the boat should approach the dock).

## **PUTTING THE EIGHT INTO THE WATER**

1. When boat is where coxswain wants it to be- “weigh-nuff” (rowing term that means stop).
2. “Sidestep it to the edge of the dock” (rowers should have their feet at the edge of the dock).
3. “Up and over heads- ready...and up!” (a description of the action to be performed before the command)
4. “Roll it down o the water- ready...and down!” (Coxswain should ensure keg does not hit dock).

## **RIGGING AND GETTING INTO THE BOAT**

1. “Starboards/Ports undo the oarlocks, Ports/Starboards get the oars” (four people should perform each task).
2. When oars are in the oarlocks- “ports/starboards oars across” (whichever side has their oars on the water side).
3. “All eight one foot center...in and down” (rowers place foot between tracks, then the other, and then sit”
4. “All eight count down from bow when ready” (starting with bow seat, rowers will shout their number when ready).

## **LAUNCHING FROM THE DOCK**

1. “All eight lean away from the dock” (before pushing off oars and riggers must be off the dock).
2. “All eight hands on the dock- ready to push...and push”

## **BEGINNING TO ROW**

1. “All eight/six/four from the finish/catch- ready...row!” (how many rowers will row and where they will start).

## **SWITCHING ROWERS WHILE ROWING**

1. “In two strokes bow pair will weigh- nuff, stern pair will row” (identify when and who will be switched).
2. “In one stroke” (coxswain counts each stroke at catch)
3. “On this stroke- bow pair out and stern pair in” (coxswain gives this command at the catch).

## **STOPPING THE BOAT**

1. “All eight/six/four weigh-nuff on my command...weigh-nuff.”
2. In an emergency- “all eight weigh-nuff and hold water.”

## **RETURNING TO THE DOCK**

1. It is very important to return to the dock at a very reduced speed.
2. “Bow six weigh-nuff, stern pair row it in nice and easy” (reduce speed by rowing with a pair only).
3. When the boat is close- “stern pair weigh-nuff, all eight lean away from the dock.”

## **GETTING OUT OF THE BOAT/ DERIGGING**

1. “All eight count down from bow when shoes are untied” (rowers will shout number when ready).
2. “All eight on foot center...up and out.”
3. Each rower removes his/her oar from the oarlock.
4. “Ports/Starboards get the oars, Starboards/Ports stay with the boat.”

## **TAKING THE BOAT OUT OF THE WATER**

1. “All eight one hand center- ready to lift over the heads...and up.”
2. Split opposite your rigger-ready...and down to the shoulders” (rowers must avoid riggers when lowering).

# APPENDIX 1: TECHNIQUE DRILLS

## POWER APPLICATION

### 1. LEGS ONLY

- Description:* Row using legs only. The blade is extracted when the legs are fully extended by pushing down on the handle while keeping the arms locked. It is important that the back remain in the catch position.
- Purpose:* To work on the proper sequence of body parts during the drive as well as the seat- oar handle connection.

### 2. ½ LEG DRIVE

- Description:* Same as above but only using half of the total leg drive.
- Purpose:* To work on the catch and initial impulse of the legs.

### 3. LOCKED ARMS ROWING

- Description:* Arms remain straight during drive and recovery. Blade is extracted by pressing down on handle while keeping arms locked. Drill can be done at any slide or stroke length- ½, ¾, backswing only.
- Purpose:* To work on suspending weight on oar handle throughout drive as well as timing of backswing during drive.

### 4. SHORT-SLIDE ROWING

- Description:* Stroke is shortened to varying lengths of slide. May include ½, ¾, 7/8 etc.
- Purpose:* To work on sequence of drive, quick pick-up of pressure, and acceleration.

### 5. ½ PRESSURE LEGS, FULL PRESSURE FINISH

- Description:* The drive is divided into two parts, legs and finish, with each being at different pressures.
- Purpose:* To work on accelerating the oar throughout the stroke. Helps to feel how the leverage of the back at the midpoint of the drive is used to accelerate the oars.

## BODY POSITION

### 1. WIDE-GRIP ROWING

- Description (Sweep Rowing):* The inside hand is placed on the carbon fiber of the oar (past the wood of the handle) so that the hands are approximately 2ft apart. This drill may be done while rowing a full stroke or combined with a drill.
- Purpose:* To set body orientation, work within the arc of the oar, and encourage the use of the outside arm to hang on the oar while minimizing the use of the inside.

### 2. PAUSE DRILLS

- Description:* During the recovery the rower pauses at a predetermined spot for several seconds before continuing with the stroke. Common stoppage points include the body set, arms away, release, and ½ slide. Stopping at each of these points will address a specific set of technical problems. All of them, however, are good as balance drills.
- Purpose:* Body Set Pause- Setting the body angle forward before the slide begins. Also slide control.  
Arms Away- Holding the shoulders back while the arms come away from the body.  
Release- Setting the boat after the blade has exited the water. Most important point for boat to be set.  
½ Slide- Body position at the catch and slide control. Helps to address lungeing.

## **BALANCE**

### **1. SHADOW ROWING**

*Description:* The entire stroke is rowed with the blade(s) feathered. It is sometimes necessary to change the pitch of the blade as the rower transitions from recovery to drive so that the blade does not get caught in the water.

*Purpose:* To work on balance and level hand paths during the drive and recovery.

### **2. GLIDES**

*Description:* The rower(s) pause at different parts of the recovery with the blades feathered and off the water. The point of the drill is to see how long the boat will remain level. This drill is usually combined with the aforementioned pause drill.

*Purpose:* To work on uniform blade height as well as balance and timing.

## **BLADEWORK**

### **1. SQUARE BLADE ROWING**

*Description:* Blades are kept square during the recovery to enforce the need for the blade to be extracted from the water before feathering. If all rowers in the boat are made to row then this drill is excellent for balance.

*Purpose:* To work on blade position at the release, also for balance and blade height on the recovery.

### **2. DELAYED FEATHER**

*Description:* Blade is kept square slightly longer than normal after the release. As above, this drill addresses the release. This is easier than square blade rowing and is often a good precursor to that drill. The advantage to this drill is that it combines an emphasis on a square blade at the release with the need for feathering.

*Purpose:* To work on blade position at the release.

### **3. ½ BLADE BURIED**

*Description:* A normal stroke is rowed with the blade buried only halfway during the entire drive. This should be done for 10-20 strokes.

*Purpose:* To teach a subtle lift off the hands at the catch and throughout the drive. This drill is excellent for addressing blade depth during the drive.

## **RECOVERY**

### **1. COUNT DRILLS**

*Description:* During the recovery the coxswain or rower counts the amount of time it takes from blade extraction to the catch.

*Purpose:* To work on slide control or the ratio of drive recovery, simply vary the amount of time it takes for the recovery. The drive should take about 1 second while the recovery should take at least 2 seconds during anything but racing cadences.

# GLOSSARY OF ROWING TERMINOLOGY

## A

- Aerobic:** Literally, "with oxygen;" refers to the use of oxygen to produce energy in muscle cells  
**Anaerobic:** Literally, "without oxygen;" refers to the two energy systems that produce energy without oxygen in the muscle cells.

## B

- Back or Backing:** Refers to sculling or rowing backwards, also used as maneuvering stroke.  
**Backstay:** Portion of the rigger used to provide stability to the pin.  
**Blade:** Part of the oar used to propel boat.  
**Bow:** The front of the boat. The bow points in the direction which you travel. Also name for rower sitting in seat closest to the front of the boat.  
**Bow Ball:** Rubber ball that can help protect the bow of a rowing shell from damage.  
**Button:** Part of the oar that keep oar from sliding through oarlock.

## C

- Catch:** Part of the stroke where the rower puts the blades into the water.  
**Check:** Force directed in opposition to the forward progress of the boat.  
**Clogs:** Type of footstretcher similar in construction to a sandal. Used in beginning rowing shells.  
**Collar:** See button.  
**Coxswain:** The person in a sweep rowing shell responsible for steering and race strategy.  
**Crab, or catch a crab:** When oar gets caught in the water during rowing stroke.  
**Crossover:** Movement of one oar handle over another, primarily the left over the right.

## D

- Deck:** material covering the top of the bow and stern sections of the boat.  
**Double:** A two-person sculling shell.  
**Drive:** The work portion of the rowing stroke when blade is squared and buried in the water.

## E

- Eight:** An eight-person sweep rowing shell with coxswain.  
**Ergometer:** A device, such as a rowing machine, used to measure the physiological effects of exercise. Commonly referred to as an "erg" or "ergo."

## F

- Feather:** Blade position during the recovery portion of stroke. Blade is held flat so that it will not catch or dig into water.  
**Fin:** The thin, flat piece projecting from the center of the bottom of a rowing shell.  
**Finish:** The portion of the stroke where the oar blade is extracted from the water.  
**Footstretchers:** The part of the boat into which you put your feet.  
**Four:** A four-person sweep rowing shell.  
**Frontstops:** Part of the track assembly that prevents the seat from sliding off the tracks.

## G

- Gate:** Part of the oarlock that may be raised or lowered to take the oar out of the oarlock or prevent it from coming out during rowing stroke.  
**Grip:** Part of a sculling oar where the hand is placed.  
**Gunwale:** The raised edges surrounding the cockpit; built to prevent water from entering.

## H

- Handle:** Part of a sweep oar where the hands are placed.

## I

**Inside hand:** In sweep rowing, the term used to denote the hand closest to the blade.

## K

**Kilometer:** Most common unit of measurement in rowing 1km = 1.2 miles.

## L

**Lactic Acid:** Compound produced by anaerobic glycolysis, which is responsible for burning in muscles during a hard workout.

## M

**Master:** A rower who is 27 years of age or older.

## O

**Oarlock:** The device that holds the oar at the end of the rigger.

**Outside Hand:** In sweep rowing, the term used to denote the hand furthest from the blade.

## P

**Pair:** A two-person sweep rowing shell.

**Piece:** A term used to describe a given period of work. Length of piece commonly measured in minutes, seconds, or kilometers.

**Pin:** The metal cylinder the oarlock swivels on.

**Port:** When facing forward towards the bow, the left side of the boat.

**Power 10:** A series of strokes when rowers increase pressure usually for strategic reasons.

## Q

**Quad:** A four person sculling shell.

**Quadriceps Muscle:** A muscle located in the thigh that is responsible for a majority of the propulsive power in the leg drive.

## R

**Rate:** The number of strokes taken per minute.

**Rigger:** The assembly projecting from the side of the rowing shell to which the oarlocks are attached. Commonly built out of metal or carbon fiber.

**Rush:** A technical problem caused by rowers sliding too quickly towards the stern.

## S

**Shell:** Another term for a rowing boat.

**Skeg:** See fin.

**Slide:** The metal channels in which the seat travels. Also used to describe the motion of the rower towards the stern of the boat.

**Starboard:** When facing forward towards the bow, the right side of the boat.

## T

**Tracks:** see slide.

## W

**Weigh Enough:** Command used in lieu of "stop!"